

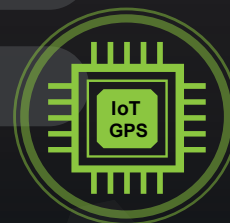

view3x

Active V-Groove Cladding Alignment Fusion Splicer

- Ultrafast Splicing & Heating
- High Magnification & Precision
- Versatile Fiber Holder
- Quick & Intuitive Interface



 Real-Time Tracking

 Report & Data Management

 Job & Work Management

 Device Management



TECHNICAL SPECIFICATIONS

Items	Specifications
Model	VIEW 3X
Alignment Method	Active V-Groove Clad Alignment
Number of Fibers	Single
Applicable Fibers	SM (ITU-T G.652&T G.657) / MM (ITU-T G.651) / DS (ITU-T G.653) / NZDS (ITU-T G.655)
Coating Diameter	100µm - 3mm
Cladding Diameter	80 - 150µm
Cleave Length	5 - 16mm
Typical Splice Loss	SM: 0.03dB / MM: 0.01dB / DS: 0.05dB / NZDS: 0.05dB / G.657: 0.03dB
Return Loss	>> 60dB
Splice Time	Quick mode: Avg. 4 sec / SM mode: Avg. 5 sec
Splice Programs	Max 128 modes
Electrode Life span	6000 Arc Discharges
Heating Programs	Max 32 modes
Heating Time	Quick: 9s / Average: 13s
Protection Sleeve	20mm - 60mm
Data Output	Cloud (View Pro Manager) + USB-C
Splice Memory	20,000 Splice data / 10,000 Splice image
Battery	Battery Capacity: 7000mAh / Operation Cycle: 350 cycles (Splicing + Heating)
Power Supply	AC Input 100 - 240V, DC Input 9 - 19V
Monitor	5.0" Color LCD display, Full Touch Screen
Magnification	x360, x520
Size	151 x 149 x 177mm
Weight	2.19kg
Pull Test	1.96 - 2.25N

*Splicing Time: Measured from the time of fibers entering the screen until the estimated loss is displayed. Splicing time can vary depending on the calibration status.

*Battery: Measured as 1-minute cycle of splicing and heating. Measured in Power Save mode.

WEIGHT AND DIMENSIONS

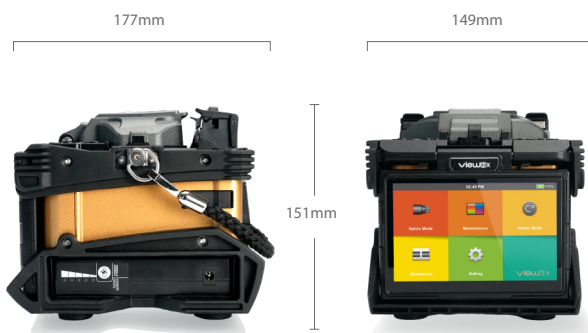

Height: 151mm
Width: 149mm
Depth: 177mm

Weight
2.19kg

ENVIRONMENTAL CONDITION & TEST

Items	Specifications
Operating Conditions	Altitude: 0 - 5000m Humidity: 0 - 95%, non-dew Temperature: -10 - 50°C Wind: up to 15m/sec
Storage Conditions	Humidity: 0 - 95%, non-dew Temperature: -40 - 80°C
Resistance Tests	Shock Resistance : 76cm for bottom surface drop Exposure to Dust : 0.1 to 500um diameter aluminium silicate Rain Resistance : 10 mm/h for 10 mins

- Water resistance (IPx2)
- Shock resistance (Drop from 76cm)
- Dust resistance (IP5X)



Water
Resistance



Shock
Resistance



Dust
Resistance

The Information on this catalog is subject to change without prior notice.

i INNO Instrument does not accept responsibility for damages arising from misuse of the product.