

8 7 6 5 4 3 2 1

D

C

B

A

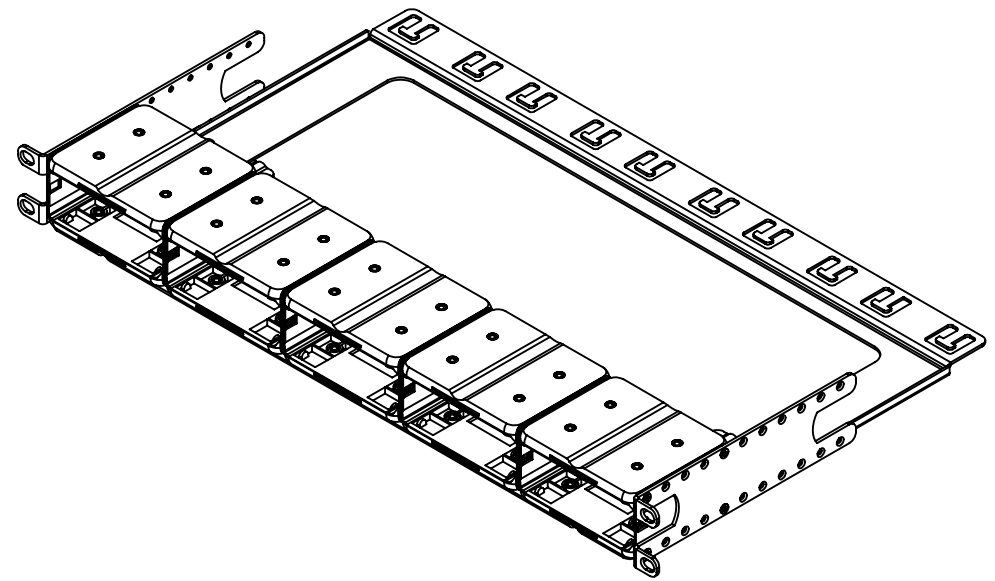
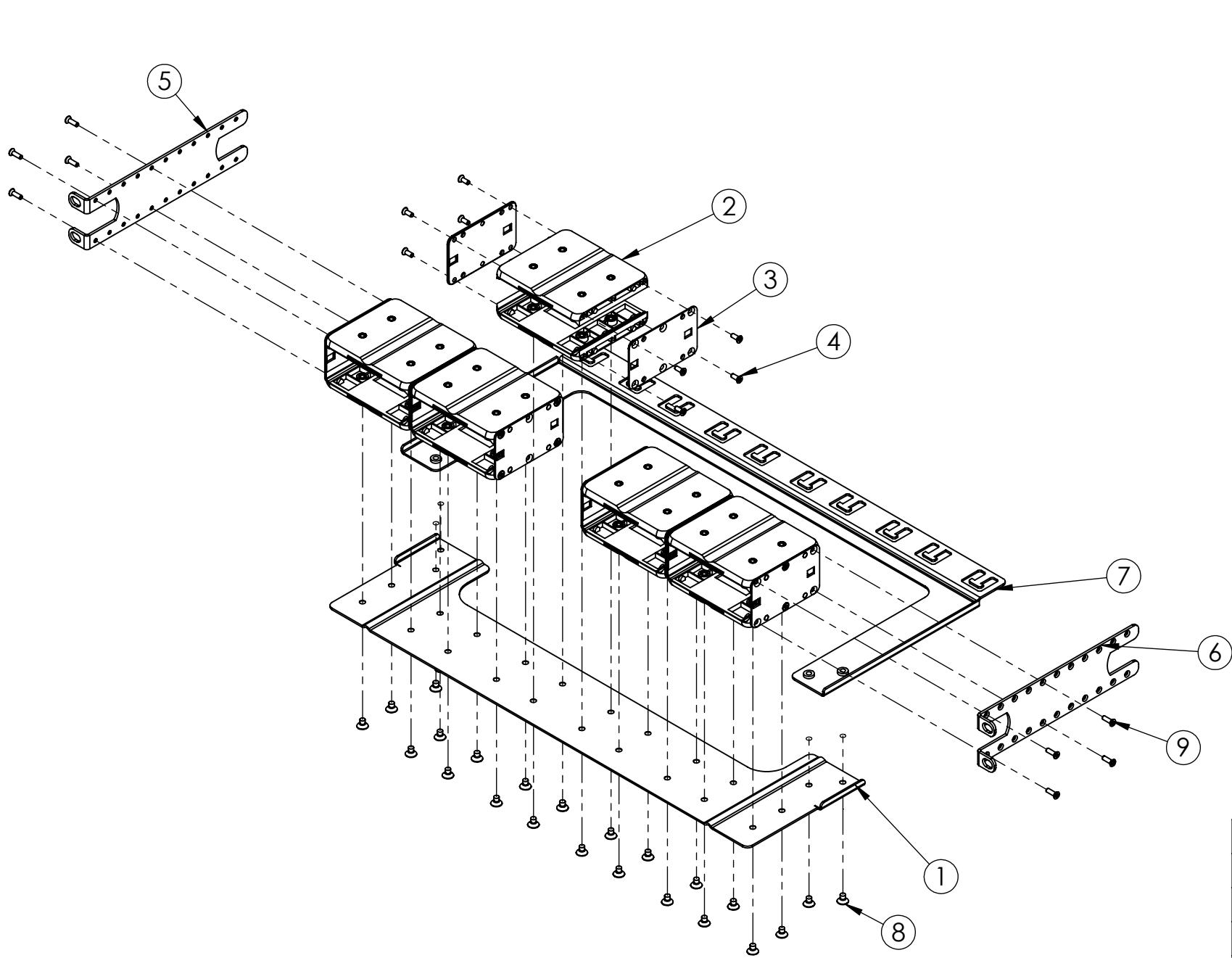

Note:
Place 4pcs cage nuts, washers and screws (178-45D/S) in the transparent ziplock bag and put into the package.

#	Description	Reference	Qty
①	1U UHD Extended Tray	FL-A-4201-1456-XX-R	1
②	Chassis End Wall	FL-A-4201-1118-XX-R	10
③	Metal Chassis Plate	FL-A-4201-1054-XX-R	10
④	ST3x8mm Cross Flat Head Screw	\	36
⑤	Mounting Bracket - Left	FL-A-4201-1458-XX-R	1
⑥	Mounting Bracket - Right	FL-A-4201-1458-XX-R	1
⑦	Rear Management Bar	FL-A-4201-0501-XX-R	1
⑧	M4x6mm Cross Flat Head Screw (Black)	\	24
⑨	ST3x10mm Cross Flat Head Screw (Black)	\	8

DRAWN		NAME		DATE		TITLE		PROD. REF.		TEST REF.	
A. Gavac		A. Gavac		04/03/2021		1U UHD Modular Panel		F-01-FF-0002		-	
SIZE	A3	DWG. #		FAMILY		PART #		AFL HYPERSCALE. Davy Avenue, Knowlhill, Milton Keynes, MK5 8HJ			
SCALE	1:4	HS-A-4201-0153-01		PART #		PART #					
		PROPRIETARY AND CONFIDENTIAL THE INFORMATION CONTAINED IN THIS DRAWING IS THE SOLE PROPERTY OF AFL HYPERSCALE Ltd. ANY REPRODUCTION IN PART OR AS A WHOLE WITHOUT THE WRITTEN PERMISSION OF AFL HYPERSCALE Ltd. IS PROHIBITED.				UNLESS OTHERWISE SPECIFIED DIMENSIONS ARE IN mm [in] TOLERANCES INTEGER NUMBER ±0.50mm ONE DECIMAL PLACE ±0.20mm TWO DECIMAL PLACES ±0.10mm ANGULAR: ±1° DO NOT SCALE DRAWING					
SHEET 1 OF 2		REV 1									

REV.	DESCRIPTION	DATE	INITIAL
1	First Release	04/03/2021	A. Gavac

8 7 6 5 4 3 2 1

D

C

B

A

8

7

6

5

4

3

2

1

D

D

C

C

B

B

A

A

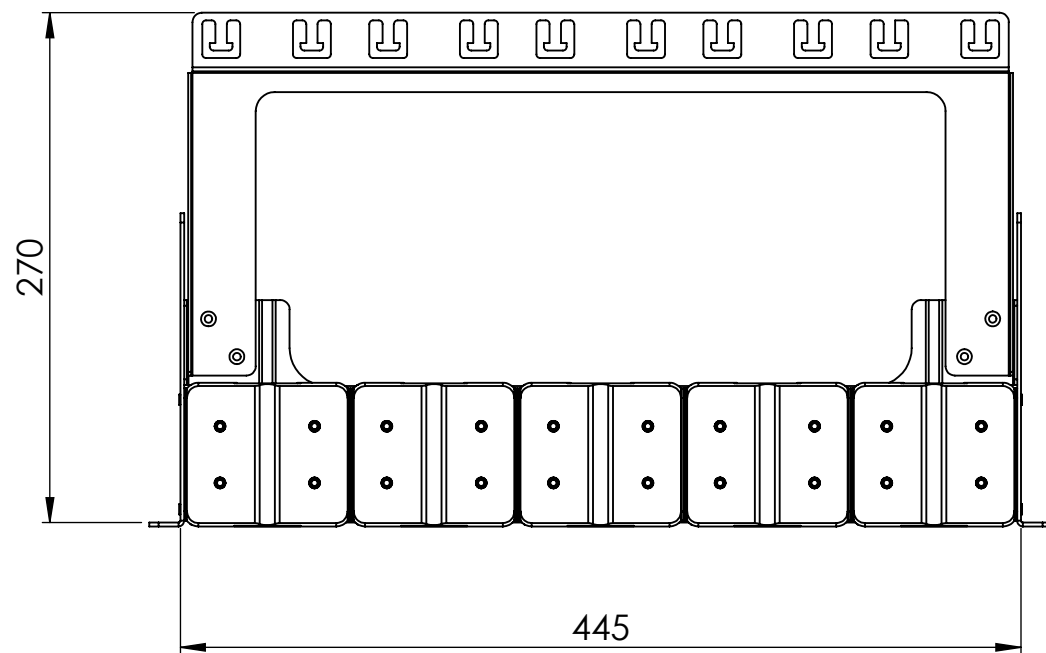
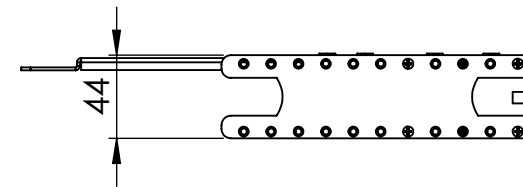
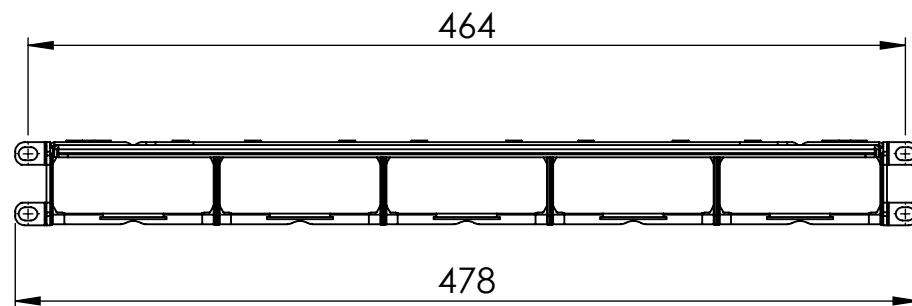

REV.	DESCRIPTION	DATE	INITIAL
1	First Release	04/03/2021	A. Gavac
REVISIONS			

DRAWN		NAME		DATE		TITLE: 1U UHD Modular Panel		PROD. REF. F-01-FF-0002		TEST REF. -	
SIZE	A3	DWG. #		HS-A-4201-0153-01		FAMILY PART #		AFL HYPERSCALE. Davy Avenue, Knowlhill, Milton Keynes, MK5 8HJ			
SCALE	1:4	PROPRIETARY AND CONFIDENTIAL		THE INFORMATION CONTAINED IN THIS DRAWING IS THE SOLE PROPERTY OF AFL HYPERSCALE Ltd. ANY REPRODUCTION IN PART OR AS A WHOLE WITHOUT THE WRITTEN PERMISSION OF AFL HYPERSCALE Ltd. IS PROHIBITED.		UNLESS OTHERWISE SPECIFIED DIMENSIONS ARE IN mm [in]					
		APPROVED AFL HYPERSCALE EC COMMITTEE						SHEET 2 OF 2		REV 1	

8

7

6

5

4

3

2

1